

Please check the examination details below before entering your candidate information

Candidate surname

Other names

Centre Number

Candidate Number

| | | | | |
|--|--|--|--|--|
| | | | | |
|--|--|--|--|--|

| | | | |
|--|--|--|--|
| | | | |
|--|--|--|--|

Pearson Edexcel International GCSE (9–1)

Time 2 hours

Paper

reference

4PH1/1P 4SD0/1P

Physics

UNIT: 4PH1

Science (Double Award) 4SD0

PAPER: 1P

You must have:

Ruler, calculator, Equation Booklet (enclosed)

Total Marks

Instructions

- Use **black** ink or ball-point pen.
- **Fill in the boxes** at the top of this page with your name, centre number and candidate number.
- Answer **all** questions.
- Answer the questions in the spaces provided
– *there may be more space than you need.*
- Show all the steps in any calculations and state the units.

Information

- The total mark for this paper is 110.
- The marks for **each** question are shown in brackets
– *use this as a guide as to how much time to spend on each question.*

Advice

- Read each question carefully before you start to answer it.
- Write your answers neatly and in good English.
- Try to answer every question.
- Check your answers if you have time at the end.

Turn over ►

P70951A

©2022 Pearson Education Ltd.

Q:1/1/1/1/1/



Pearson

FORMULAE

You may find the following formulae useful.

energy transferred = current \times voltage \times time

$$E = I \times V \times t$$

$$\text{frequency} = \frac{1}{\text{time period}}$$

$$f = \frac{1}{T}$$

$$\text{power} = \frac{\text{work done}}{\text{time taken}}$$

$$P = \frac{W}{t}$$

$$\text{power} = \frac{\text{energy transferred}}{\text{time taken}}$$

$$P = \frac{W}{t}$$

$$\text{orbital speed} = \frac{2\pi \text{ orbital radius}}{\text{time period}}$$

$$v = \frac{2\pi r}{T}$$

(final speed)² = (initial speed)² + (2 \times acceleration \times distance moved)

$$v^2 = u^2 + (2 \times a \times s)$$

pressure \times volume = constant

$$p_1 \times V_1 = p_2 \times V_2$$

$$\frac{\text{pressure}}{\text{temperature}} = \text{constant}$$

$$\frac{p_1}{T_1} = \frac{p_2}{T_2}$$

Where necessary, assume the acceleration of free fall, $g = 10 \text{ m/s}^2$.

DO NOT WRITE IN THIS AREA

DO NOT WRITE IN THIS AREA

DO NOT WRITE IN THIS AREA



DO NOT WRITE IN THIS AREA

DO NOT WRITE IN THIS AREA

DO NOT WRITE IN THIS AREA

Answer ALL questions.

Some questions must be answered with a cross ☒. If you change your mind about an answer, put a line through the box ☒ and then mark your new answer with a cross ☒.

1 The diagram shows a comet as it moves through part of its orbit around the Sun.

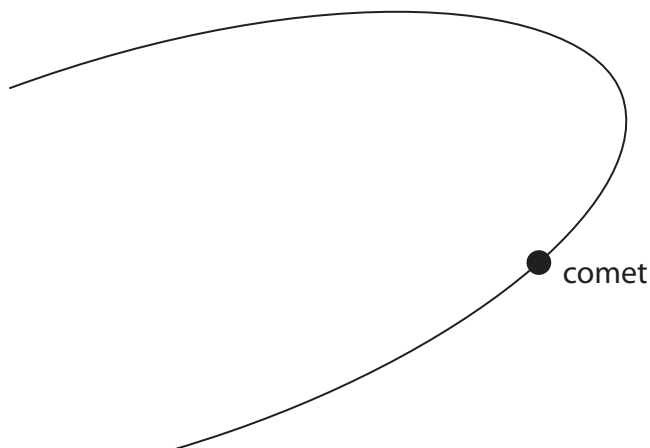

- (a) (i) Add an S to the diagram to show the position of the Sun. (1)
- (ii) Complete the diagram to show the orbit of the comet. (2)
- (iii) Add an X to the diagram to show the position where the comet is moving fastest. (1)
- (b) Describe how the orbit of a comet compares with the orbit of a planet. (3)

.....

.....

.....

.....

.....

.....

(Total for Question 1 = 7 marks)



2 (a) Which statement describes the term **atomic number** for a nucleus?

(1)

- A number of electrons in the nucleus
- B number of neutrons in the nucleus
- C number of protons in the nucleus
- D number of protons and neutrons in the nucleus

(b) Which statement describes the term **mass number** for a nucleus?

(1)

- A number of electrons in the nucleus
- B number of neutrons in the nucleus
- C number of protons in the nucleus
- D number of protons and neutrons in the nucleus

(c) Which statement describes the term **isotopes**?

(1)

- A atoms with the same number of electrons but a different number of protons
- B atoms with the same number of neutrons but a different number of electrons
- C atoms with the same number of neutrons but a different number of protons
- D atoms with the same number of protons but a different number of neutrons



(d) An atom contains 8 protons, 8 neutrons and 8 electrons.

Which of these would result in a negatively charged ion of the same element?

(1)

- A** adding an electron
- B** adding a proton
- C** removing an electron
- D** removing a proton

(e) It is not possible to predict exactly when a radioactive nucleus will decay.

Which feature of radioactive decay best explains this observation?

(1)

- A** radioactive decay can change the structure of the nucleus
- B** radioactive decay happens at random
- C** radioactive decay is irreversible
- D** radioactive decay makes a nucleus more stable

(f) Which of these is the correct unit for measuring the activity of a radioactive sample?

(1)

- A** becquerel (Bq)
- B** coulomb (C)
- C** joule (J)
- D** watt (W)

(Total for Question 2 = 6 marks)



- 3 An ultrasonic distance-measuring device can be used to measure the length of a room.

The device emits a pulse of sound with a frequency of 40 kHz.

The device also emits a bright beam of red visible light.

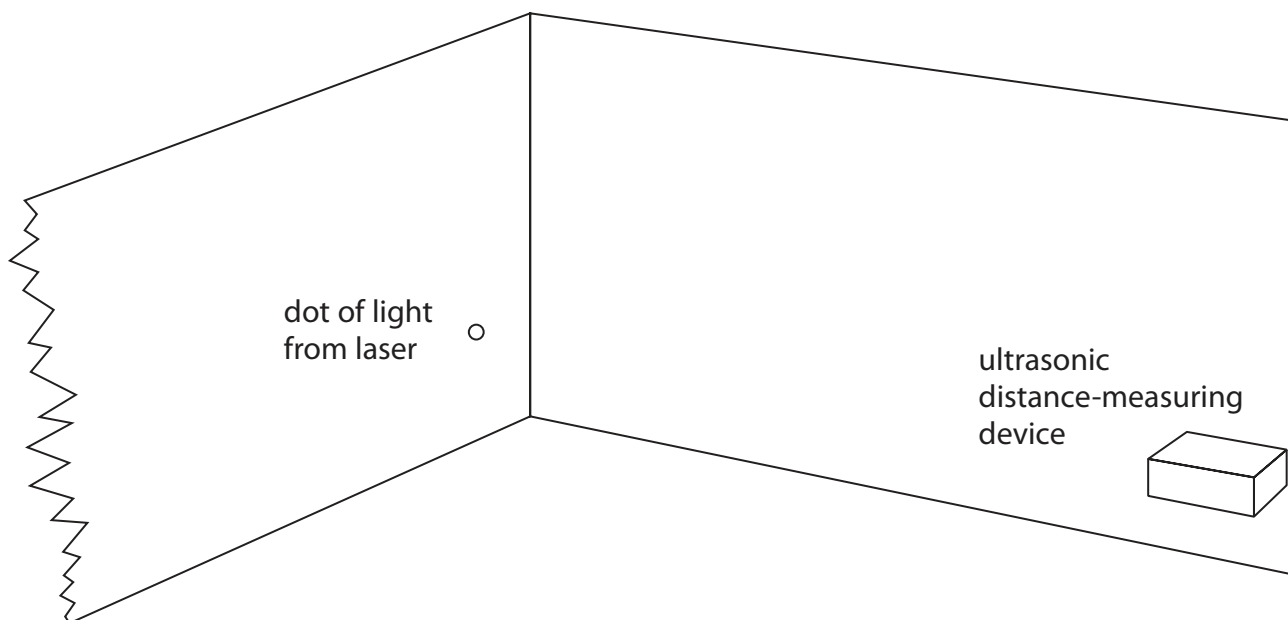

- (a) Explain what is meant by a frequency of 40 kHz.

(2)

.....

.....

.....

.....



(b) A sound wave from the device travels at 345 m/s.

(i) State the formula linking wave speed, frequency and wavelength. (1)

(ii) Calculate the wavelength of the sound wave. (3)

wavelength = m

(iii) The device emits a sound wave.

The sound wave travels to the wall, reflects back to the device and is received by the device.

The distance from the device to the wall is 2.35 m.

Calculate the time between the sound wave being emitted and received by the device.

(4)

time = s

(c) Suggest why the device emits visible light. (1)

.....
.....
.....



(d) Sound waves and light waves can have different frequencies and wavelengths.

Describe three other differences between sound waves and light waves.

You may draw diagrams to support your answer.

(3)

.....

.....

.....

.....

.....

.....

.....

(Total for Question 3 = 14 marks)



DO NOT WRITE IN THIS AREA

DO NOT WRITE IN THIS AREA

DO NOT WRITE IN THIS AREA

BLANK PAGE



4 The table gives data for some of the planets in the solar system.

| Planet | Gravitational field strength at surface in N/kg | Orbital radius in km | Orbital speed in km/s |
|---------|---|----------------------|-----------------------|
| Mercury | 3.7 | 57.9×10^6 | 47.4 |
| Venus | 8.9 | 108.2×10^6 | 35.0 |
| Jupiter | 23.1 | 778.6×10^6 | 13.1 |
| Saturn | 9.0 | 1433.5×10^6 | 9.7 |
| Uranus | 8.7 | 2872.5×10^6 | 6.8 |
| Neptune | 12.7 | 4495.1×10^6 | 5.4 |

(a) Plot a bar chart of the gravitational field strength for each planet.

(3)

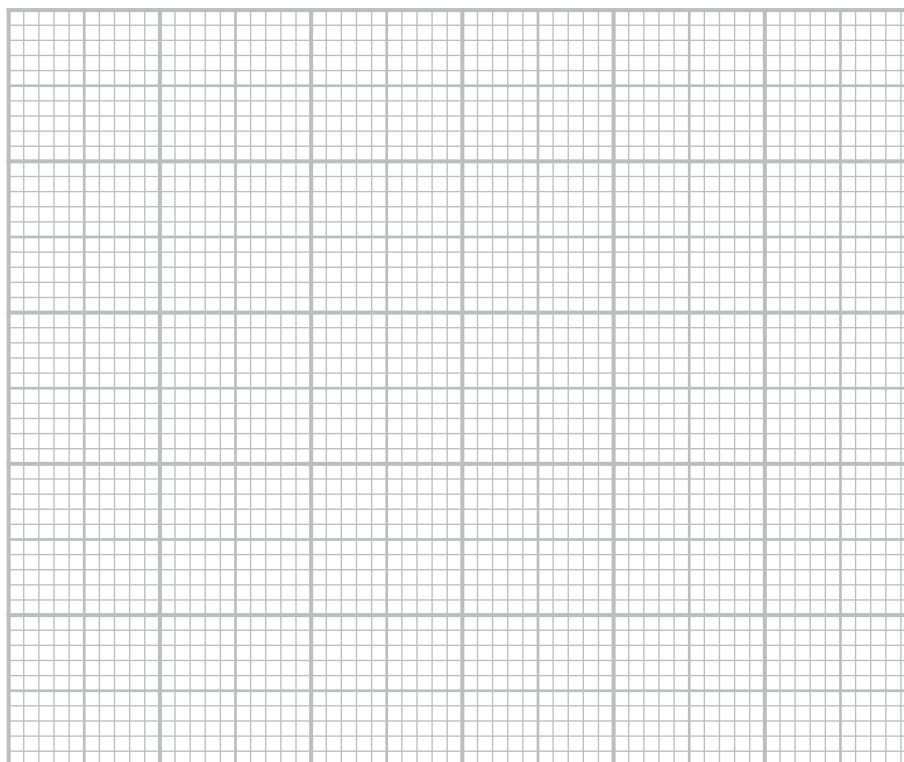

DO NOT WRITE IN THIS AREA

DO NOT WRITE IN THIS AREA

DO NOT WRITE IN THIS AREA

(b) Suggest why planets have different gravitational field strengths at their surface. (1)

.....
.....
.....

(c) Give the relationship shown by the data in the table between the orbital radius and the orbital speed for the planets in the solar system. (1)

.....
.....
.....

(d) Calculate the time period of Mercury’s orbit around the Sun. (3)

time period = s

(Total for Question 4 = 8 marks)

5 A material called granite is used as a work surface in a kitchen.



(Source: Ksana_uk/Shutterstock)

(a) Granite is formed naturally and contains radioactive isotopes.

The granite work surface contributes to the background radiation in the kitchen.

Give another naturally occurring source of background radiation.

(1)

DO NOT WRITE IN THIS AREA

DO NOT WRITE IN THIS AREA

DO NOT WRITE IN THIS AREA



(b) Granite contains the isotope thorium-232 (${}_{90}^{232}\text{Th}$).

Thorium-232 decays by a sequence of alpha decays and beta decays to form radon-220 (${}_{86}^{220}\text{Rn}$).

(i) State two differences between alpha radiation and beta radiation.

(2)

1

.....

2

.....

(ii) The incomplete nuclear decay equation summarises the decay sequence of thorium-232 into radon-220.



Calculate the number of alpha particles and the number of beta particles emitted in this decay sequence.

(3)

number of alpha particles =

number of beta particles =



(c) Thorium-232 is a solid and remains in the work surface.

Radon-220 is a gas and is emitted from the work surface.

Thorium-232 and radon-220 both emit alpha radiation.

Discuss the hazards due to the granite work surface when a person is working in the kitchen.

Refer to contamination and irradiation in your answer.

(3)

.....

.....

.....

.....

.....

.....

.....

.....

.....

.....

(Total for Question 5 = 9 marks)



DO NOT WRITE IN THIS AREA

DO NOT WRITE IN THIS AREA

DO NOT WRITE IN THIS AREA

6 The diagram shows a child on a zip-line ride.

During the ride the child slides along a metal wire with the velocity in the direction shown in the diagram.

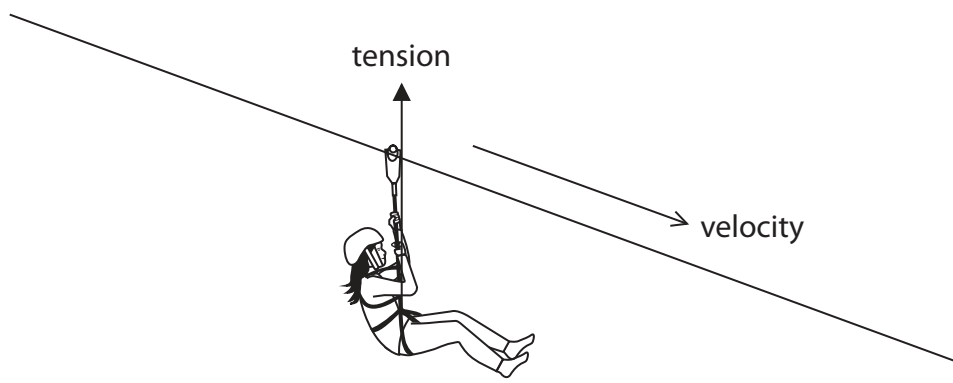

The diagram also shows the tension force acting on the safety harness the child is wearing.

(a) Force and velocity are examples of vector quantities.

State what is meant by the term **vector quantity**.

(1)

(b) Draw labelled arrows on the diagram to show two other forces that act on the child.

(4)

(Total for Question 6 = 5 marks)



7 (a) State what is meant by the term **electric current**.

(1)

(b) Diagram 1 shows an electric circuit used to test a fuse.

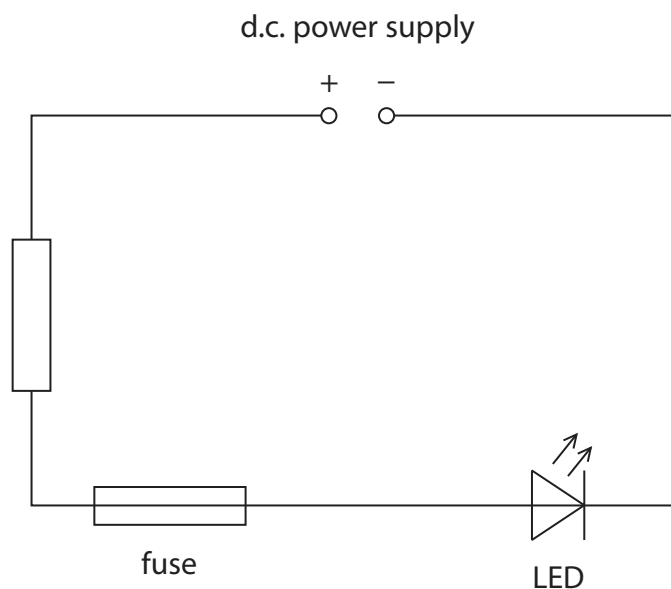

Diagram 1

(i) Give a reason why an LED is included in the circuit.

(1)

(ii) Add another component to the circuit in diagram 1 to measure the current in the fuse.

(1)



(c) Diagram 2 shows a different electric circuit containing three different lamps.

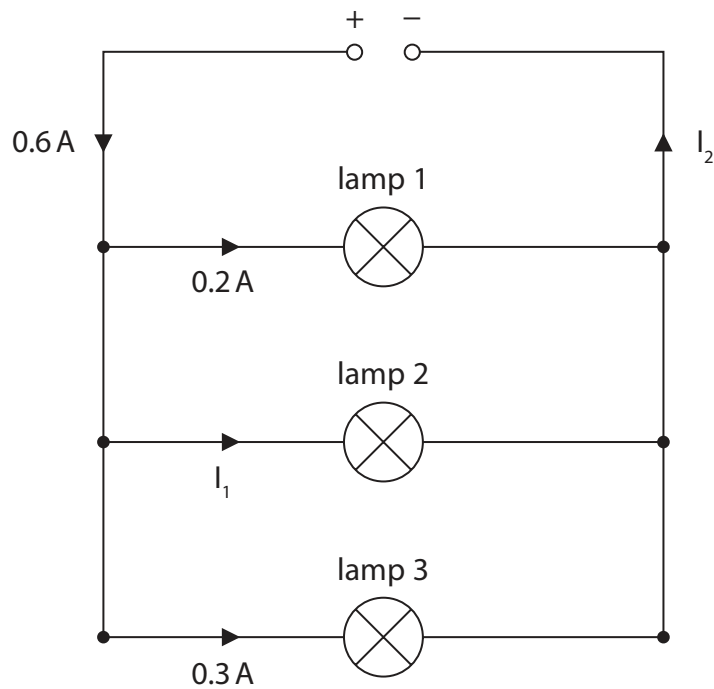

Diagram 2

(i) Calculate the current I_1 . (1)

$I_1 = \dots\dots\dots$ A

(ii) State the current I_2 . (1)

$I_2 = \dots\dots\dots$ A

(iii) Explain which lamp is the brightest. (3)

.....

.....

.....

.....

.....

.....

.....

(Total for Question 7 = 8 marks)



- 8 The photograph shows a toy car. When the toy car is pulled backwards, energy is stored in the elastic store as the rubber band is twisted.

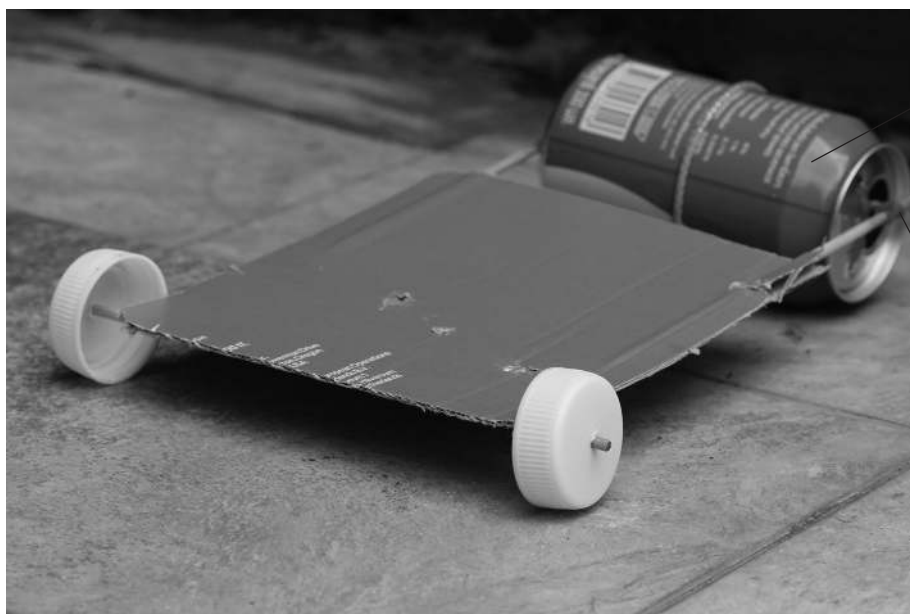

(Source: Mama Belle and the kids/Shutterstock)

When the car is released, some of the energy from the elastic store is transferred to the kinetic store of the car.

The remaining energy is transferred into the thermal store of the surroundings.

- (a) State what is meant by the principle of conservation of energy.

(1)

- (b) The car is pulled backwards so that there is 165 J of energy in its elastic store.

When the car is released, this energy is transferred to the car's kinetic energy store with an efficiency of 15%.

- (i) State the formula linking efficiency, useful energy output and total energy output.

(1)



(ii) Calculate the energy transferred into the thermal store of the surroundings.

(4)

energy transferred to thermal store = J

(iii) Draw a labelled Sankey diagram for this energy transfer.

(3)

DO NOT WRITE IN THIS AREA

DO NOT WRITE IN THIS AREA

DO NOT WRITE IN THIS AREA



P 7 0 9 5 1 A 0 1 9 3 2

(c) The car is pulled backwards again.

When released, 45 J of energy transfers into the car's kinetic store.

The car travels a distance of 7.5 m during this energy transfer.

(i) State the useful work done on the car.

(1)

work done = J

(ii) Calculate the mean accelerating force acting on the car.

(3)

accelerating force = N

(Total for Question 8 = 13 marks)



- 9 (a) Diagram 1 shows a plastic bottle containing water.

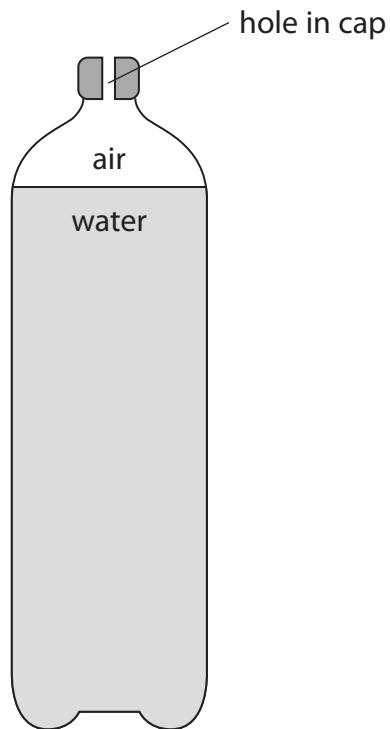

Diagram 1

- (i) State the formula linking pressure difference, height, density and gravitational field strength, g .

(1)

- (ii) The pressure difference between the surface of the water and the water at the bottom of the bottle is 2300 Pa.

Calculate the depth of water in the bottle.

Give your answer in cm.

[density of water = 1000 kg/m^3]

(3)

depth = cm

(b) Three holes are made in the bottle at positions A, B and C.

Diagram 2 shows the path of the water leaving the bottle from hole B.

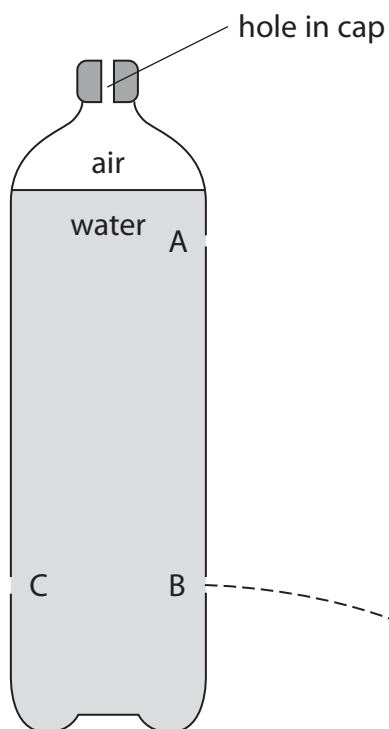

Diagram 2

(i) Draw a line on diagram 2 to show the path of the water leaving the bottle from hole A.

(1)

(ii) Explain the path of the water leaving the bottle from hole A.

(2)



(iii) Hole C is at the same depth in the bottle as hole B but on the opposite side of the bottle.

Explain the shape of the path of the water leaving the bottle from hole C.

(3)

.....

.....

.....

.....

.....

.....

.....

.....

.....

.....

.....

(iv) Suggest why there is a hole in the cap of the bottle.

(1)

.....

.....

.....

(Total for Question 9 = 11 marks)

DO NOT WRITE IN THIS AREA

DO NOT WRITE IN THIS AREA

DO NOT WRITE IN THIS AREA



10 The photograph shows a vertical drop ride at an amusement park.

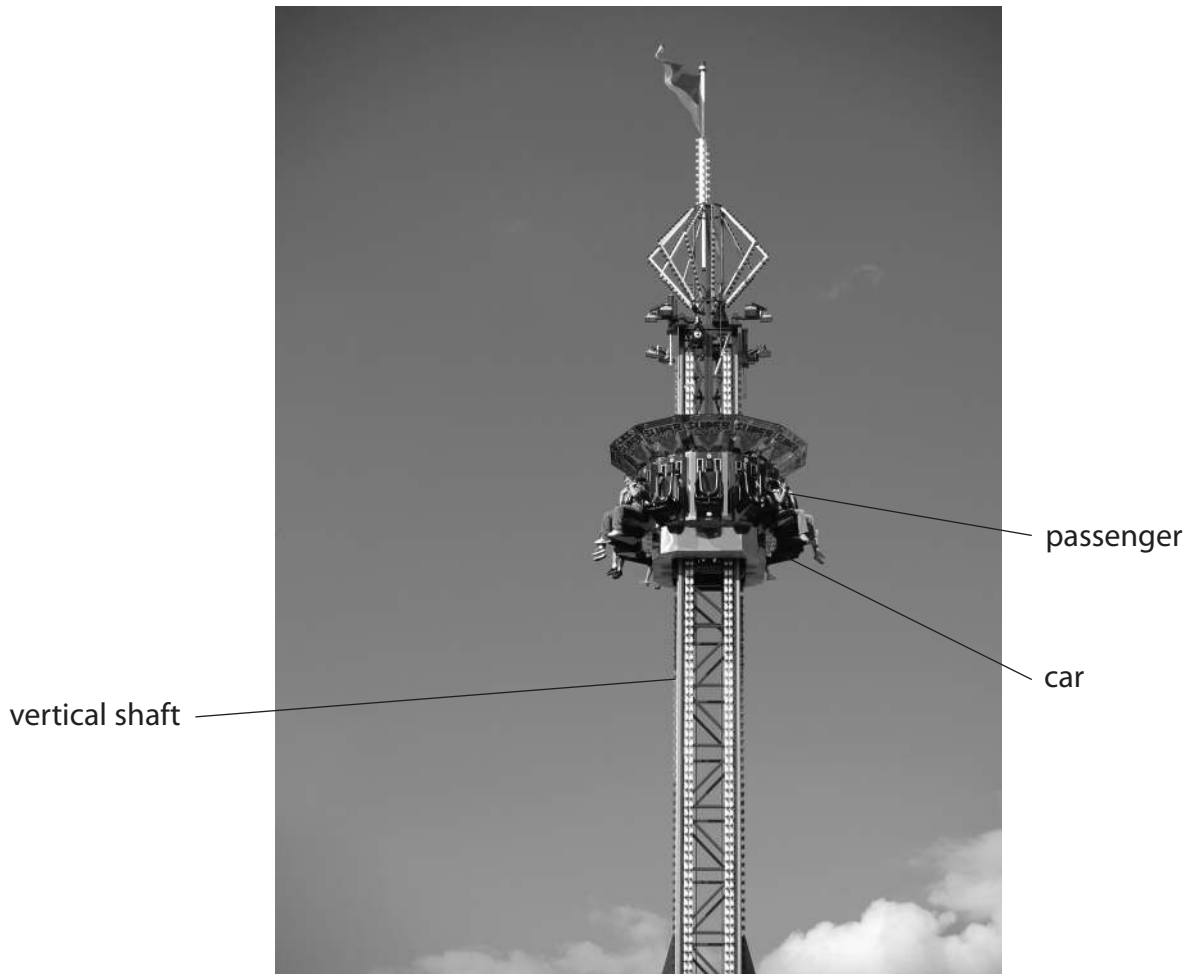

(Source: Kenneth Sponsler/Shutterstock)

The car is pulled to the top of a vertical shaft and then released from rest.

The car then falls freely because of the force of gravity.

(a) Calculate the speed of the car when it has fallen 18 m.

(3)

speed = m/s

DO NOT WRITE IN THIS AREA

DO NOT WRITE IN THIS AREA

DO NOT WRITE IN THIS AREA



(b) (i) State the formula linking kinetic energy, mass and speed. (1)

(ii) The mass of the car and its passengers is 2.1 tonnes.
Calculate the kinetic energy of the car when it has fallen 18 m.
[1 tonne = 1000 kg] (2)

kinetic energy = J

(c) The actual speed of the car when it has fallen 18 m is lower than the value calculated in (a).
Describe the energy transfers occurring from immediately before the car was released to when the car has fallen 18 m.
Refer to stores and transfers in your answer. (4)

.....

.....

.....

.....

.....

.....

.....

.....

.....

.....

(Total for Question 10 = 10 marks)



11 A steel ball is fired from a launcher on an adjustable table.

A student investigates how the range of the steel ball varies with the height of the table.

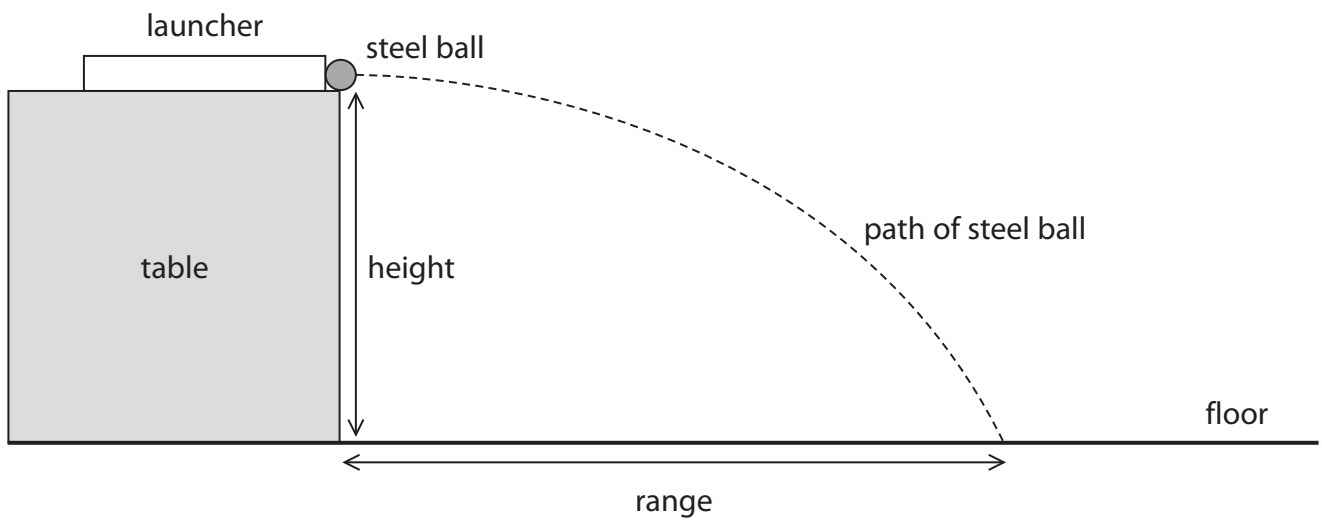

DO NOT WRITE IN THIS AREA

DO NOT WRITE IN THIS AREA

DO NOT WRITE IN THIS AREA



DO NOT WRITE IN THIS AREA

DO NOT WRITE IN THIS AREA

DO NOT WRITE IN THIS AREA

(a) Describe a method for the student's investigation.

Your answer should include details of

- the variables in the investigation
- how the investigation will be valid (a fair test)
- how the range will be measured accurately

(6)

Area with horizontal dotted lines for writing the answer.



(b) The graph shows the student's results.

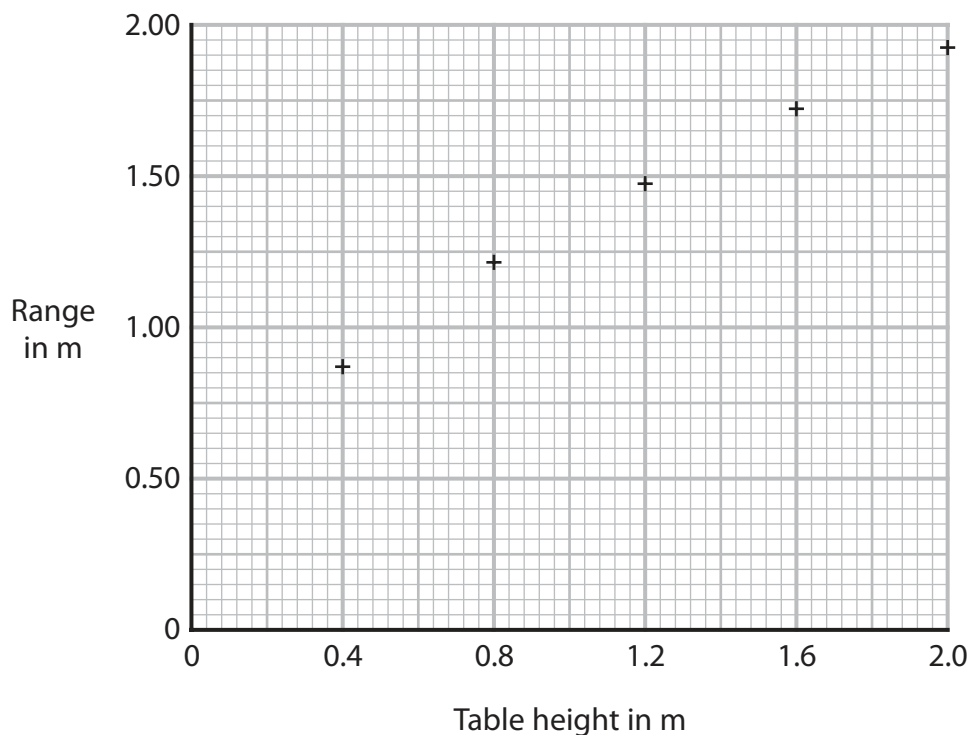

(i) Draw the curve of best fit.

(1)

(ii) Estimate what the height of the table would be when the range of the projectile is 0.60 m.

(1)

height = m

(iii) Justify why the student has plotted a line graph rather than a bar chart.

(1)

.....

.....

.....



(iv) The range of the projectile is related to the table height by this formula

$$\text{range} = \text{launch speed} \times \sqrt{\frac{\text{table height}}{5}}$$

Using data from the graph, show that the launch speed of the projectile is approximately 3 m/s.

(4)

launch speed = m/s

(Total for Question 11 = 13 marks)

DO NOT WRITE IN THIS AREA

DO NOT WRITE IN THIS AREA

DO NOT WRITE IN THIS AREA



P 7 0 9 5 1 A 0 2 9 3 2

12 (a) Photograph 1 shows part of an ammeter that can measure very small currents.



Photograph 1

A student moves a wire between the poles of a strong magnet and uses the ammeter to measure the induced current.

Determine the current reading shown by the ammeter in photograph 1.

(1)

current = mA

- (b) (i) Predict a value for the current if the movement of the wire was repeated with the poles of the magnet reversed.

(1)

current = mA

- (ii) Predict a value for the current if the wire is moved faster between the poles of the magnet.

(1)

current = mA



- (c) Photograph 2 shows the structure of the ammeter.
The ammeter has a needle attached to a coil of wire which can move freely around a magnet.
When there is a current in the coil, the needle moves.
The larger the current, the more the coil turns.

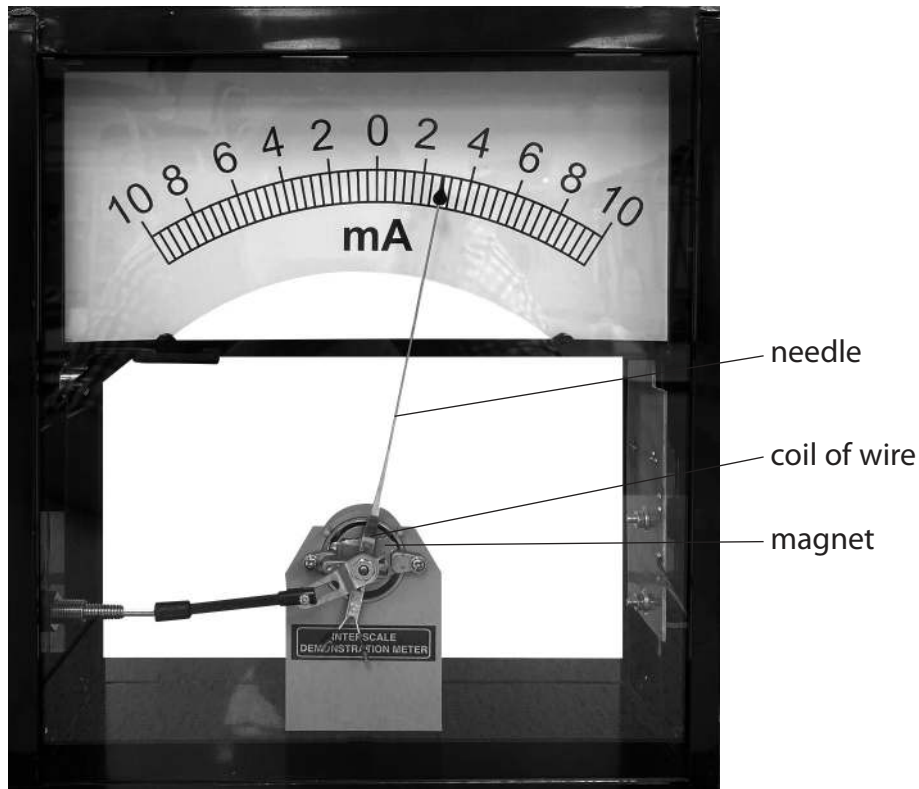

Photograph 2

Suggest how the design of the ammeter could be modified to increase its sensitivity.

(1)

QUESTION 12 CONTINUES ON NEXT PAGE

- (d) Photograph 3 shows part of the ammeter after a student has adjusted the ammeter in error.

The needle on the ammeter does not point to zero when there is no current.



Photograph 3

- (i) Which of these factors has been decreased by the student's adjustment? (1)
- A** accuracy
 - B** precision
 - C** reliability
 - D** resolution

- (ii) Suggest how the student could correct the readings taken from this ammeter due to this error without adjusting the ammeter. (1)

(Total for Question 12 = 6 marks)

TOTAL FOR PAPER = 110 MARKS



Pearson Edexcel International GCSE (9–1)

May–June 2022 Assessment Window

Paper
reference

4PH1/1P 4SD0/1P

Physics

UNIT: 4PH1

Science (Double Award) 4SD0

PAPER: 1P

Equation Booklet

Do not return this Booklet with the question paper.

Turn over ►

P70951A

©2022 Pearson Education Ltd.

Q:1/1/1/1/1/



P 7 0 9 5 1 A

Pearson

These equations may be required for both International GCSE Physics (4PH1) and International GCSE Combined Science (4SD0) papers.

1. Forces and Motion

$$\text{average speed} = \frac{\text{distance moved}}{\text{time taken}}$$

$$\text{acceleration} = \frac{\text{change in velocity}}{\text{time taken}} \qquad a = \frac{(v-u)}{t}$$

$$(\text{final speed})^2 = (\text{initial speed})^2 + (2 \times \text{acceleration} \times \text{distance moved})$$

$$v^2 = u^2 + (2 \times a \times s)$$

$$\text{force} = \text{mass} \times \text{acceleration} \qquad F = m \times a$$

$$\text{weight} = \text{mass} \times \text{gravitational field strength} \qquad W = m \times g$$

2. Electricity

$$\text{power} = \text{current} \times \text{voltage} \qquad P = I \times V$$

$$\text{energy transferred} = \text{current} \times \text{voltage} \times \text{time} \qquad E = I \times V \times t$$

$$\text{voltage} = \text{current} \times \text{resistance} \qquad V = I \times R$$

$$\text{charge} = \text{current} \times \text{time} \qquad Q = I \times t$$

$$\text{energy transferred} = \text{charge} \times \text{voltage} \qquad E = Q \times V$$

3. Waves

$$\text{wave speed} = \text{frequency} \times \text{wavelength} \qquad v = f \times \lambda$$

$$\text{frequency} = \frac{1}{\text{time period}} \qquad f = \frac{1}{T}$$

$$\text{refractive index} = \frac{\sin(\text{angle of incidence})}{\sin(\text{angle of refraction})} \qquad n = \frac{\sin i}{\sin r}$$

$$\sin(\text{critical angle}) = \frac{1}{\text{refractive index}} \qquad \sin c = \frac{1}{n}$$



4. Energy resources and energy transfers

$$\text{efficiency} = \frac{\text{useful energy output}}{\text{total energy output}} \times 100\%$$

$$\text{work done} = \text{force} \times \text{distance moved} \quad W = F \times d$$

$$\text{gravitational potential energy} = \text{mass} \times \text{gravitational field strength} \times \text{height}$$

$$GPE = m \times g \times h$$

$$\text{kinetic energy} = \frac{1}{2} \times \text{mass} \times \text{speed}^2 \quad KE = \frac{1}{2} \times m \times v^2$$

$$\text{power} = \frac{\text{work done}}{\text{time taken}} \quad P = \frac{W}{t}$$

5. Solids, liquids and gases

$$\text{density} = \frac{\text{mass}}{\text{volume}} \quad \rho = \frac{m}{V}$$

$$\text{pressure} = \frac{\text{force}}{\text{area}} \quad p = \frac{F}{A}$$

$$\text{pressure difference} = \text{height} \times \text{density} \times \text{gravitational field strength}$$

$$p = h \times \rho \times g$$

$$\frac{\text{pressure}}{\text{temperature}} = \text{constant} \quad \frac{p_1}{T_1} = \frac{p_2}{T_2}$$

$$\text{pressure} \times \text{volume} = \text{constant} \quad p_1 \times V_1 = p_2 \times V_2$$

8. Astrophysics

$$\text{orbital speed} = \frac{2 \times \pi \times \text{orbital radius}}{\text{time period}} \quad v = \frac{2 \times \pi \times r}{T}$$

The equations on the following page will only be required for International GCSE Physics.

These additional equations may be required in International GCSE Physics papers 2P and 2PR.

1. Forces and Motion

momentum = mass \times velocity $p = m \times v$

force = $\frac{\text{change in momentum}}{\text{time taken}}$ $F = \frac{(mv - mu)}{t}$

moment = force \times perpendicular distance from the pivot

5. Solids, liquids and gases

change in thermal energy = mass \times specific heat capacity \times change in temperature

$$\Delta Q = m \times c \times \Delta T$$

6. Magnetism and electromagnetism

relationship between input and output voltages for a transformer

$$\frac{\text{input (primary) voltage}}{\text{output (secondary) voltage}} = \frac{\text{primary turns}}{\text{secondary turns}}$$

input power = output power

$$V_p I_p = V_s I_s$$

for 100% efficiency

8. Astrophysics

$$\frac{\text{change in wavelength}}{\text{reference wavelength}} = \frac{\text{velocity of a galaxy}}{\text{speed of light}} \quad \frac{\lambda - \lambda_0}{\lambda_0} = \frac{\Delta \lambda}{\lambda_0} = \frac{v}{c}$$

END OF EQUATION LIST

